

Anexa 1 , la Regulamentul Tehnic National de Karting

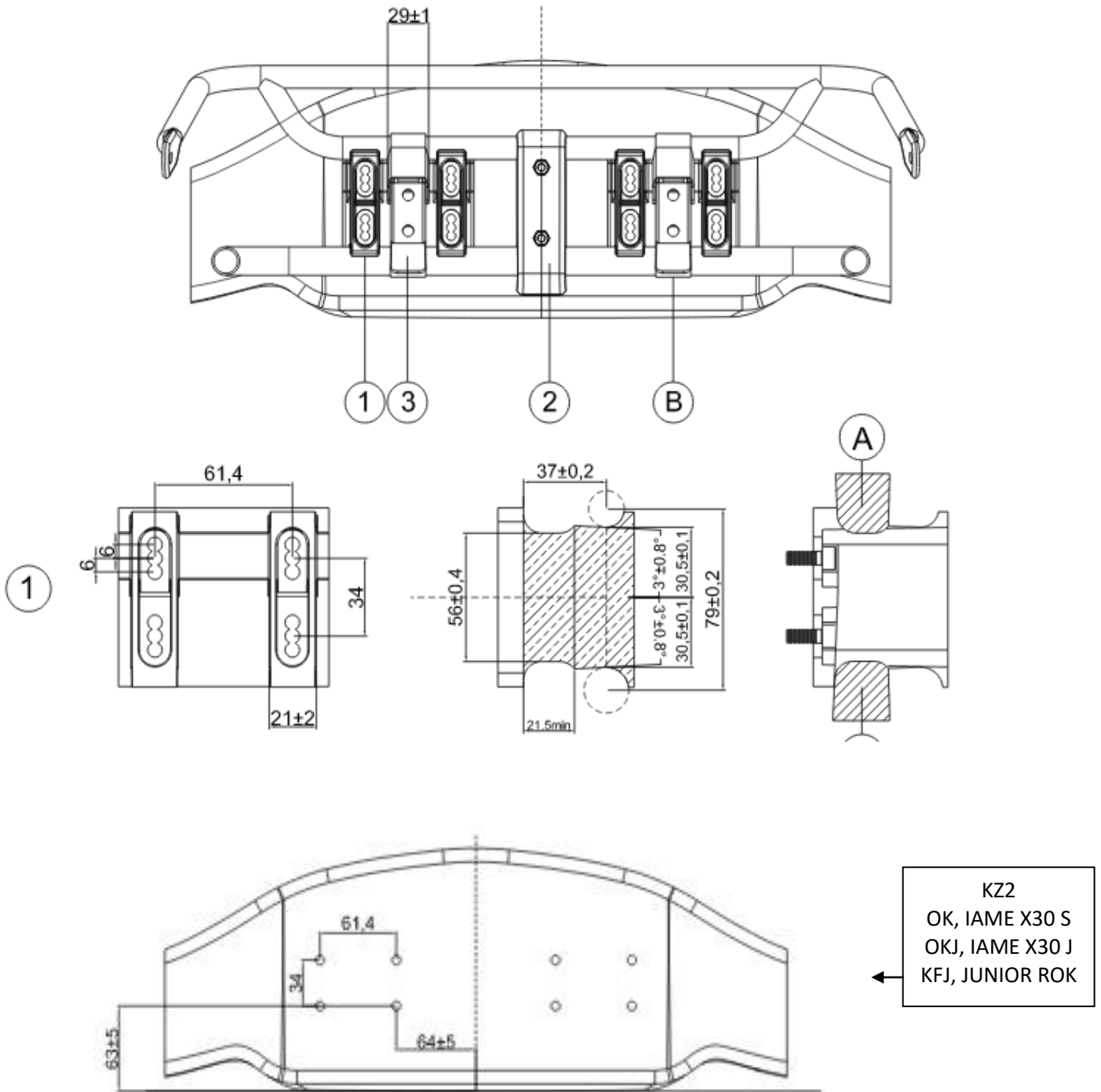

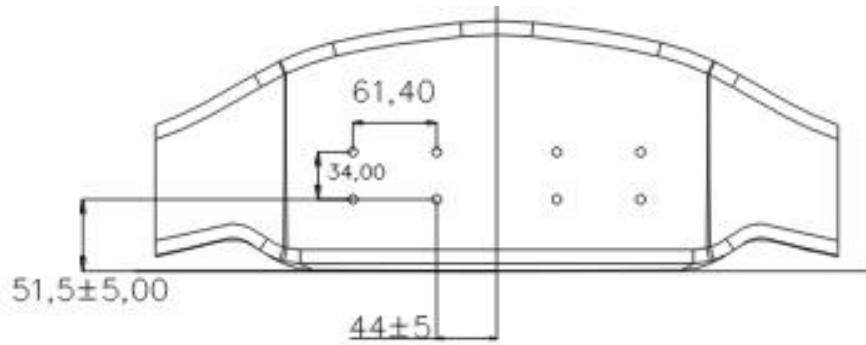

← MINI,MINI ROK
PUFO,MICRO ROK

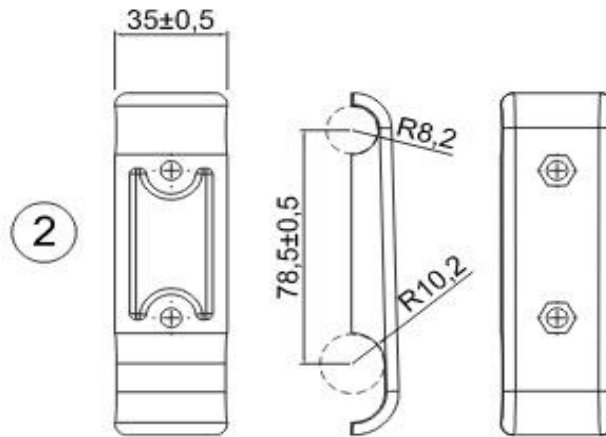

- 1-suport fixare carenaj frontal(2 piese din plastic+8 suruburi)
- 2-suport parasoc fata(2 semicarcase din plastic+2 suruburi)
- 3-cleme de inchidere reglabile(2 piese din metal)

Instalarea corecta a carenajului frontal

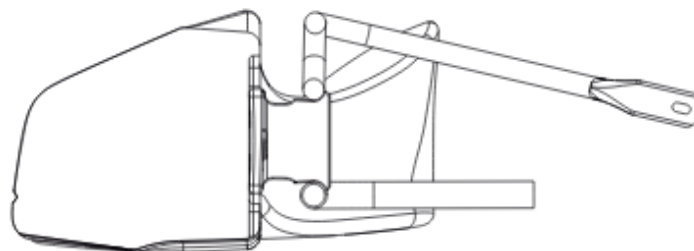

-pozitie acceptata

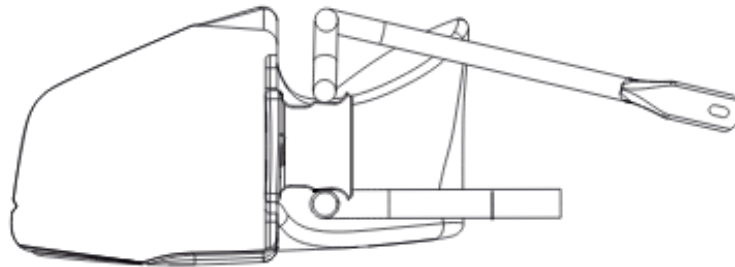

-pozitii neacceptate daca orice parte a tevilor parasocului
fata se afla in zona **A**.

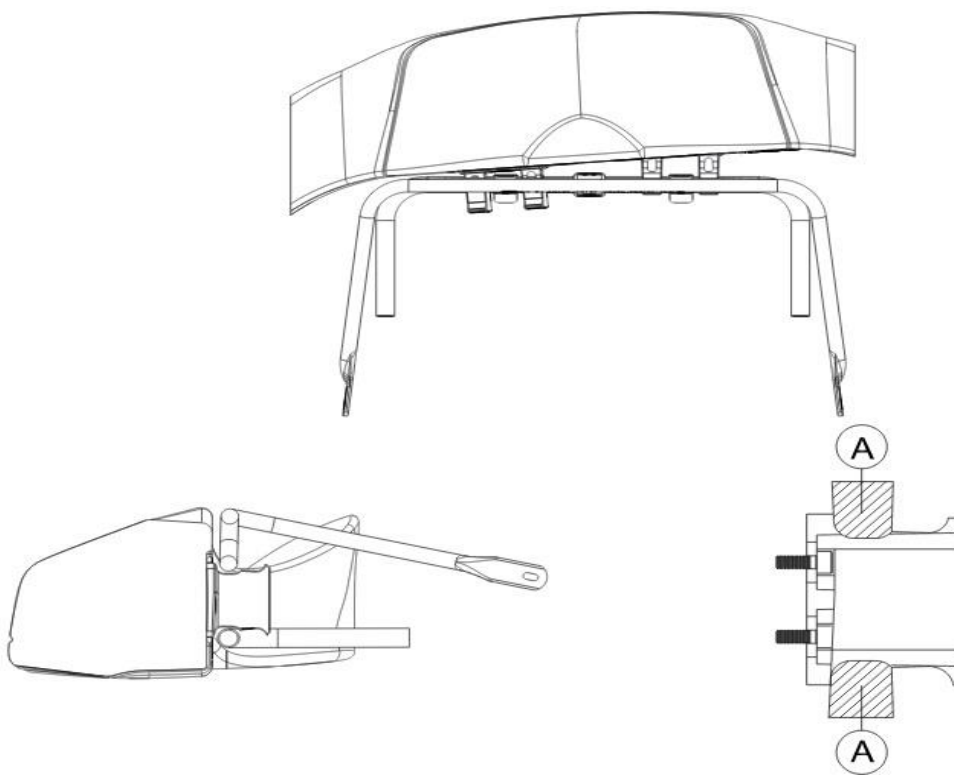

Presedinte CTOP
Muresan Petru-Rares

A handwritten signature in blue ink, corresponding to the name Muresan Petru-Rares.